

3D-S027 德国 U 型潜水艇 XXI 式

Legends:

- E Engraved side
- NE Non-engraved side
- Attention point
- Insert tab and bend 90 degrees
- Insert tab and twist 90 degrees

Recommended tools:

- Wire cutters: helpful for taking parts from the metal sheets.
- Tweezers or needle nose pliers: helpful for folding parts, bending and twisting tabs.

Assembly tip:
If needed, slightly twist tabs to hold parts together then untwist and bend them down for a nice finish

Assembly Flow Chart

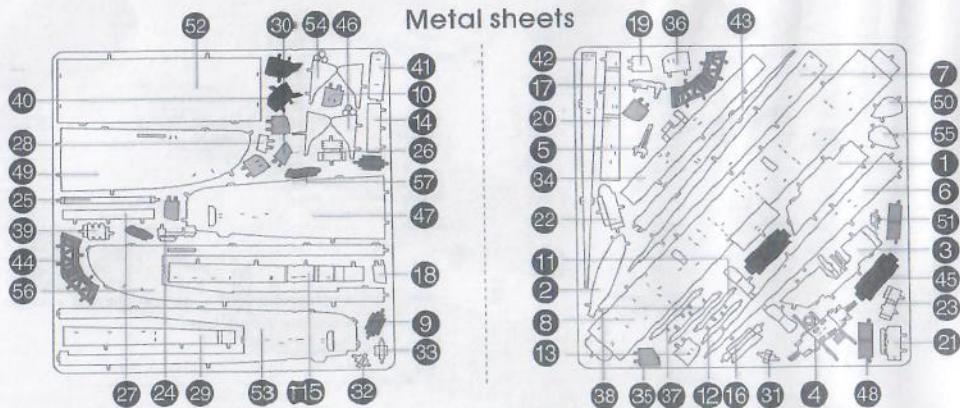
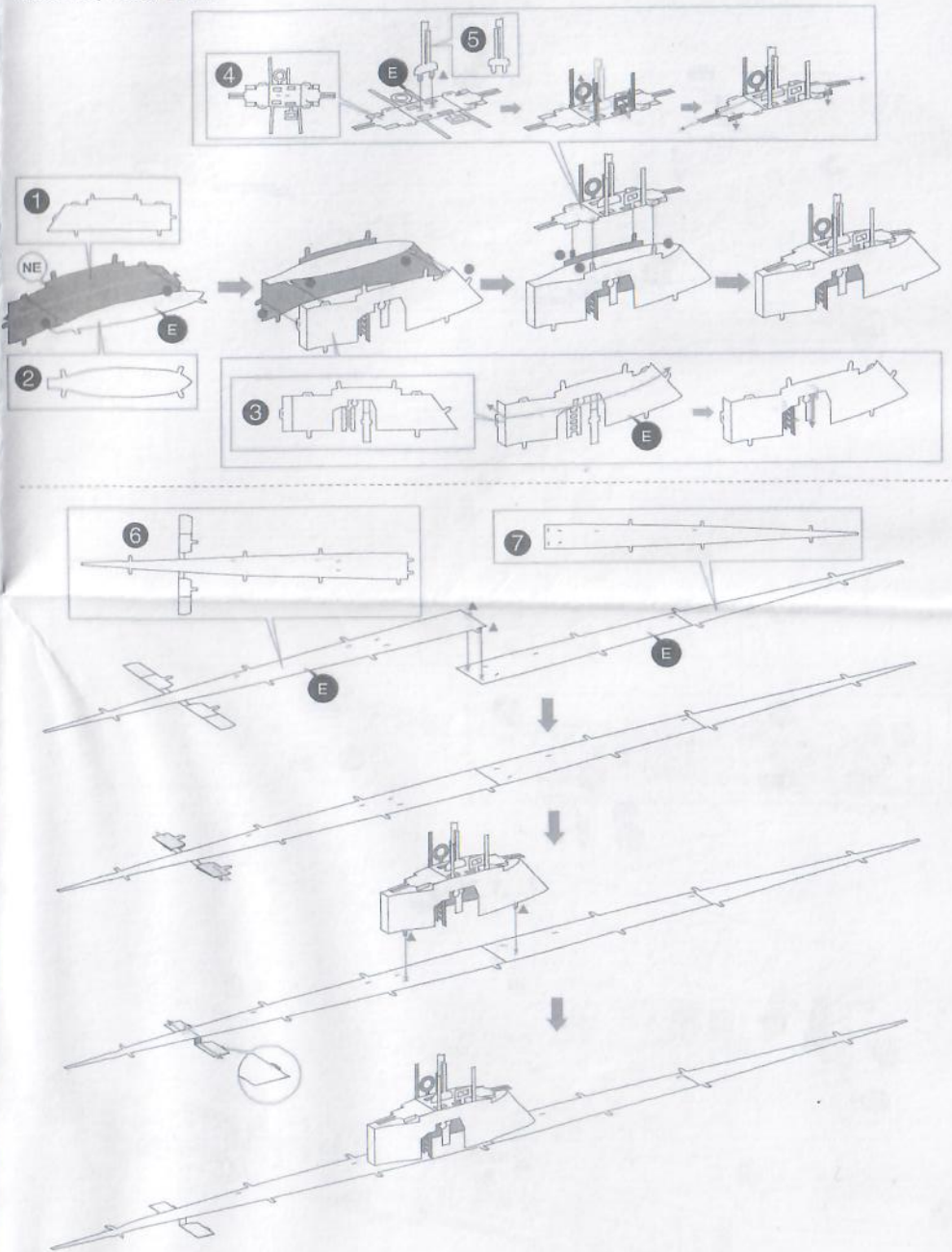

In order to avoid possible injury from sharp edges, please carefully discard the metal sheet after parts have been removed

