

X-wing Star Fighter™

Assembly Flow Chart

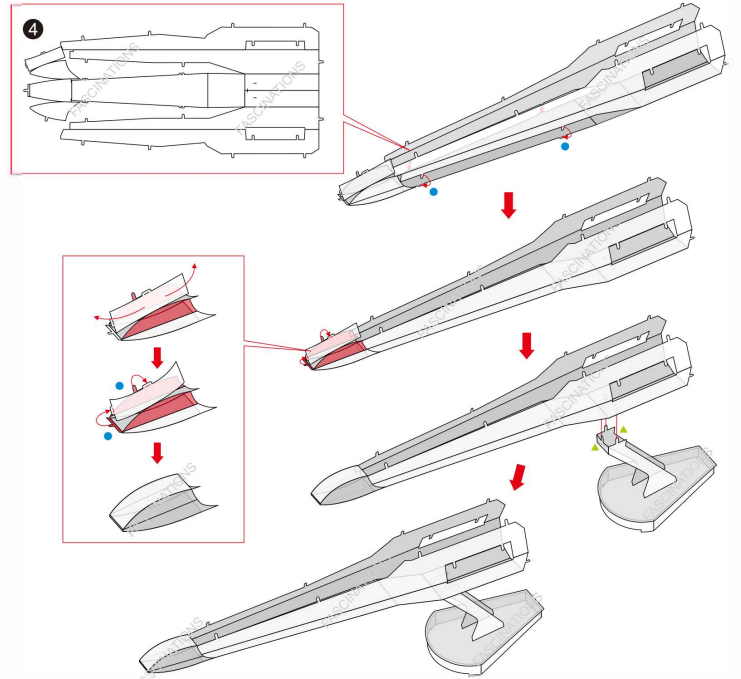
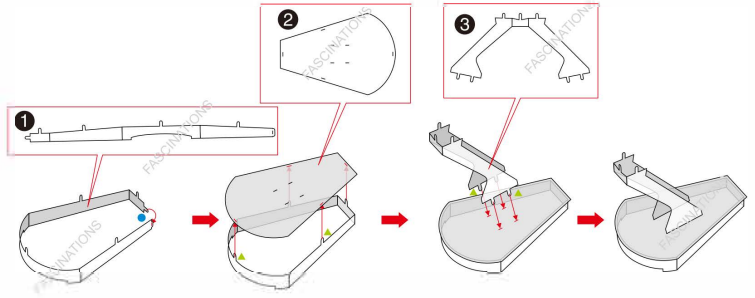

Legends:

- E** Engraved side
- NE** Non-engraved side
- Hand icon** Attention point
- Blue circle** Insert tab and bend 90 degrees
- Yellow triangle** Insert tab and twist 90 degrees

Recommended tools:

- Wire cutters: helpful for taking parts from the metalsheets.
- Tweezers or needle nose pliers: helpful for folding parts, bending and twisting tabs.

Assembly tip:
If needed, slightly twist tabs to hold parts together then untwist and bend them down for a nice finish.

Diagram labels:
Insertion tabs are inserted and then folded.
Insertion holes.
Fold lines can be seen as shown here.

Metal sheets

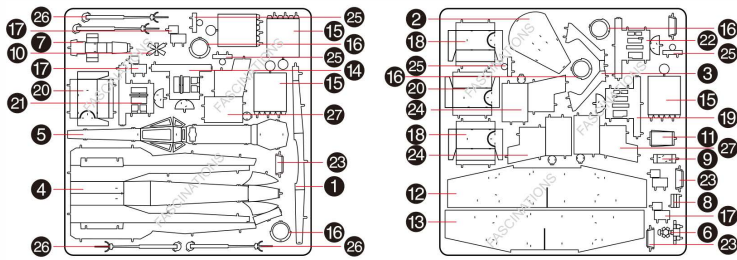

⚠ In order to avoid possible injury from sharp edges, please carefully discard the metal sheet after parts have been removed

