

Imperial TIE Fighter™

360° view

**Legends:**

- E** Engraved side
- NE** Non-engraved side
- Attention point
- Insert tab and bend 90 degrees
- Insert tab and twist 90 degrees

**Recommended tools:**

- Wire cutters: helpful for taking parts from the metal sheets.
- Tweezers or needle nose pliers: helpful for folding parts, bending and twisting tabs.

**Assembly tip:**  
If needed, slightly twist tabs to hold parts together then untwist and bend them down for a nice finish

Metal sheets

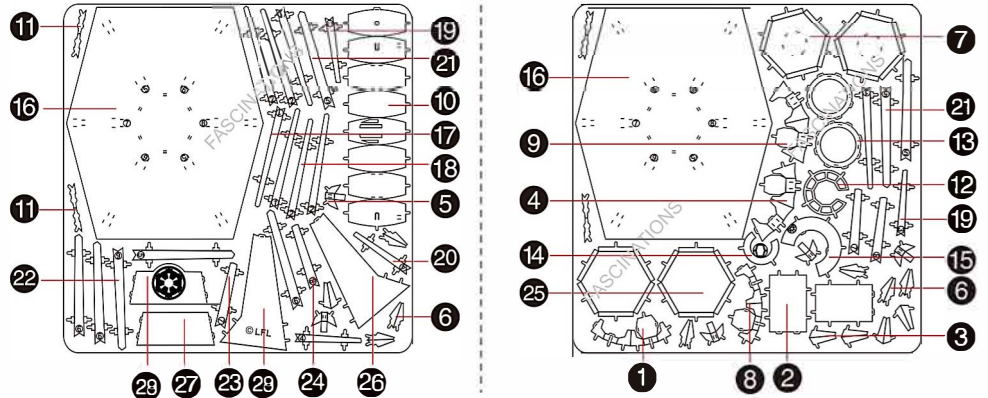

In order to avoid possible injury from sharp edges, please carefully discard the metal sheets after parts have been removed

Assembly Flow Chart

