

3D METAL MODEL 3D 金屬模型

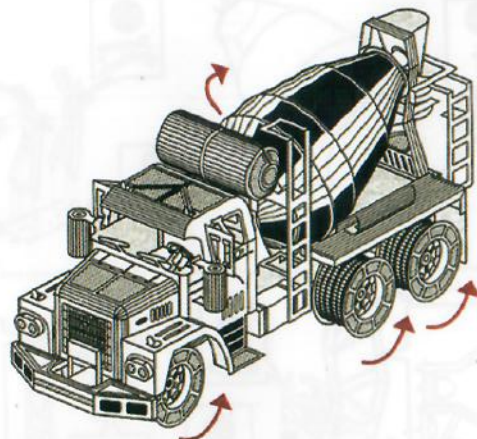

CAUTION / 注意:

- Keep out of reach of children. 請放置于幼童接觸不到的地方。
- Warning, small parts. 請留意細小部件。
- Pay attention to sharp edges when removing pieces from the metal sheet. 取下零件時，請注意邊緣的銳點，避免劃傷。
- Carefully discard the metal sheet after parts have been removed. 零件取下後，小心處理剩餘金屬片。

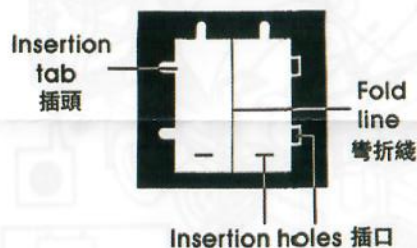

To create the best connections

建立穩固的連接的方法:

- Insert tab and bend 90 degrees for most visible areas
插頭穿過插孔後，將插頭最大限度
地拉出，並平折成90度角。
- ▲ Insert tab and twist 90 degrees is best in some areas to ensure a tight connection
插頭穿過插孔後，將插頭作90度旋轉扭曲，
可在某些部位形成緊密的連接。

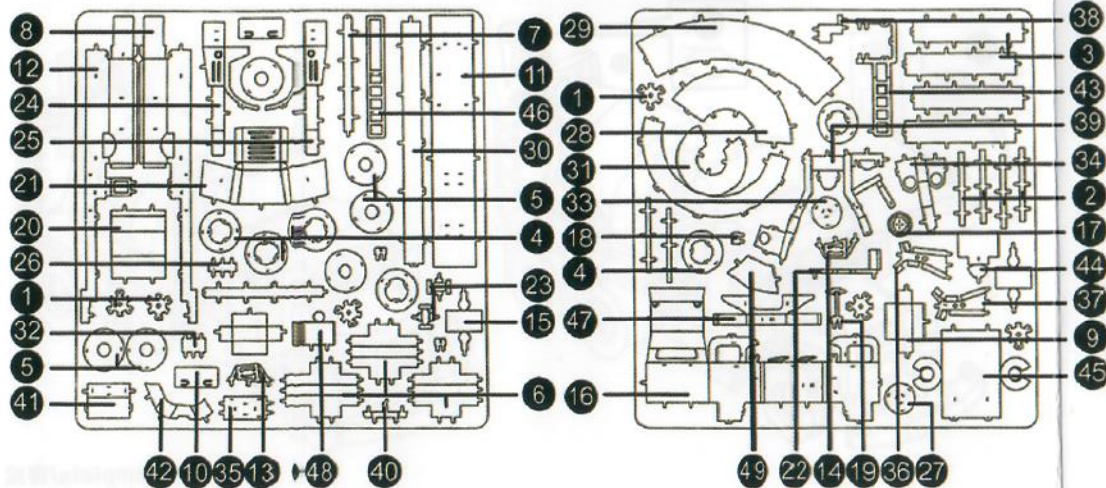

ASSEMBLY METHOD: Follow assembly flow chart. 請按以下示意圖拼裝。

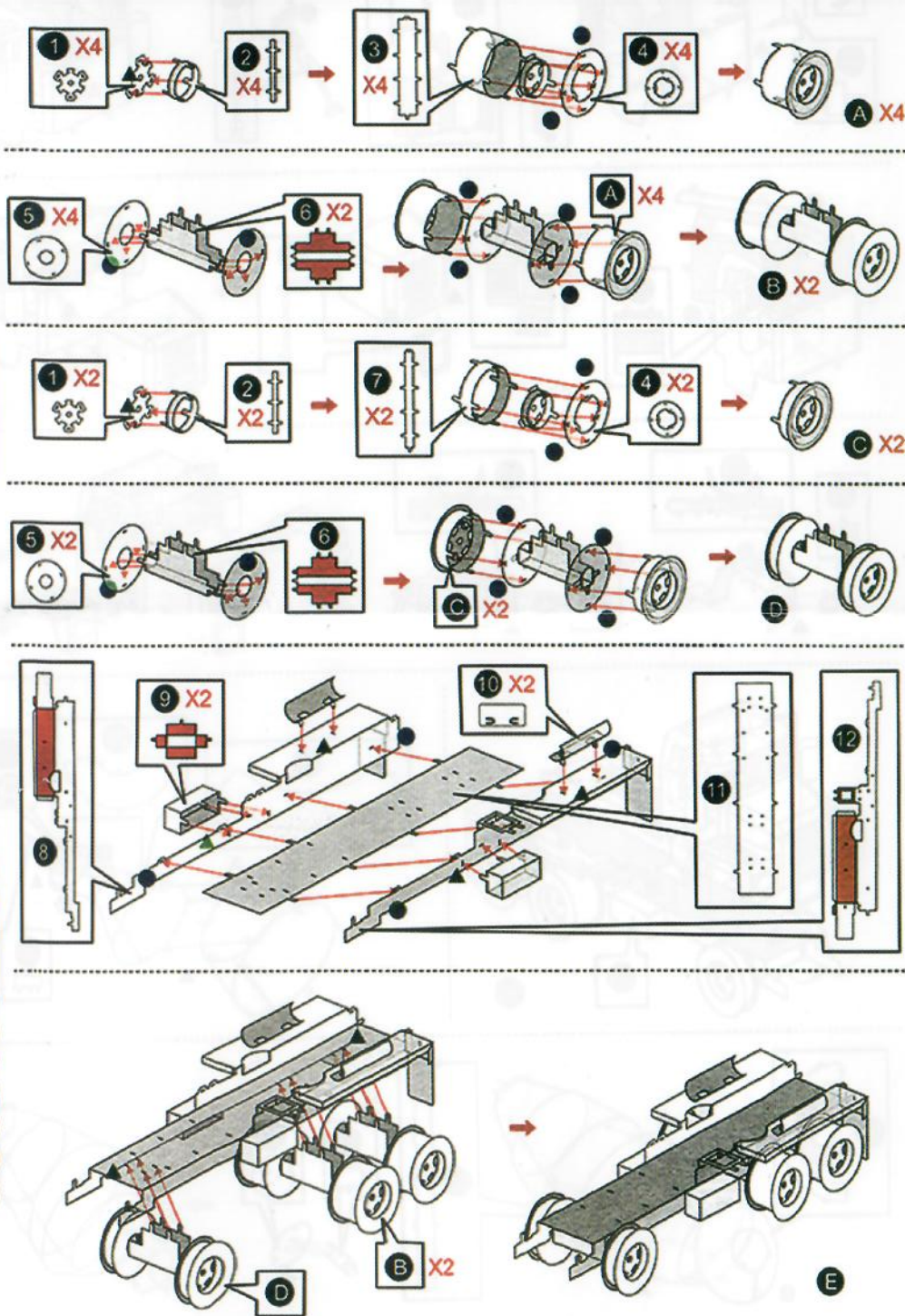

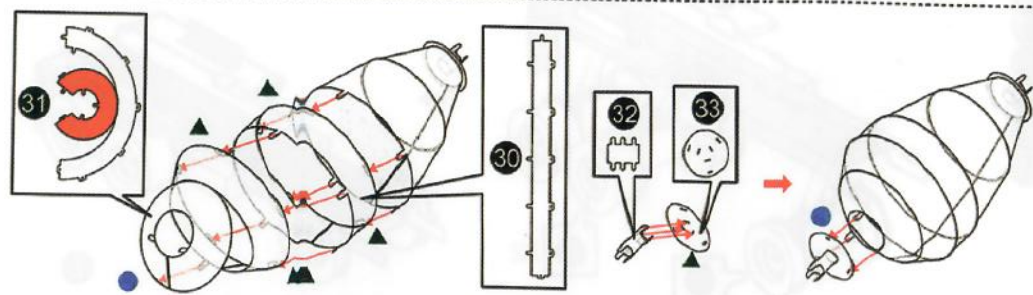
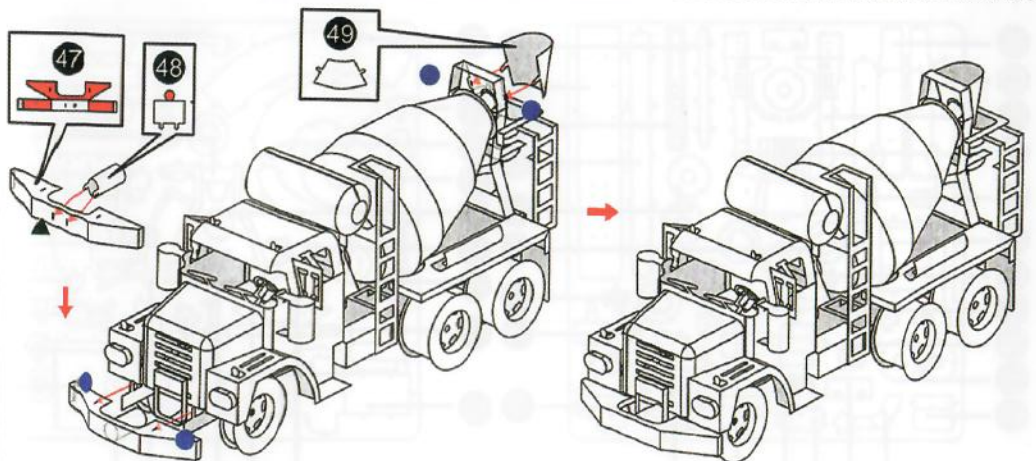
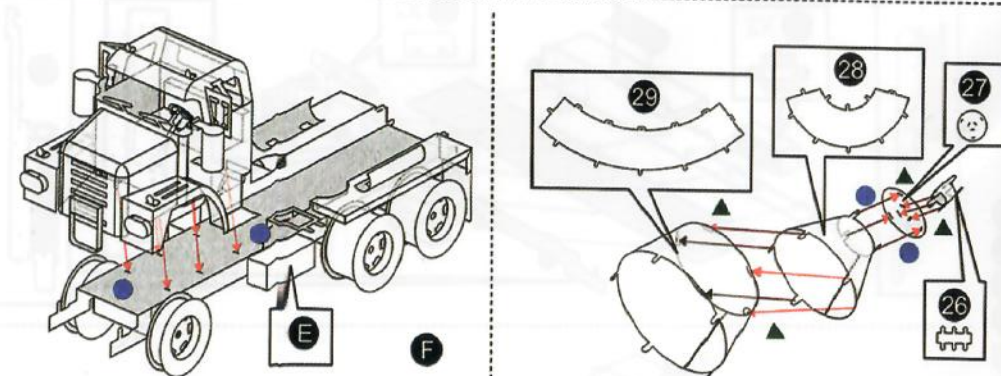
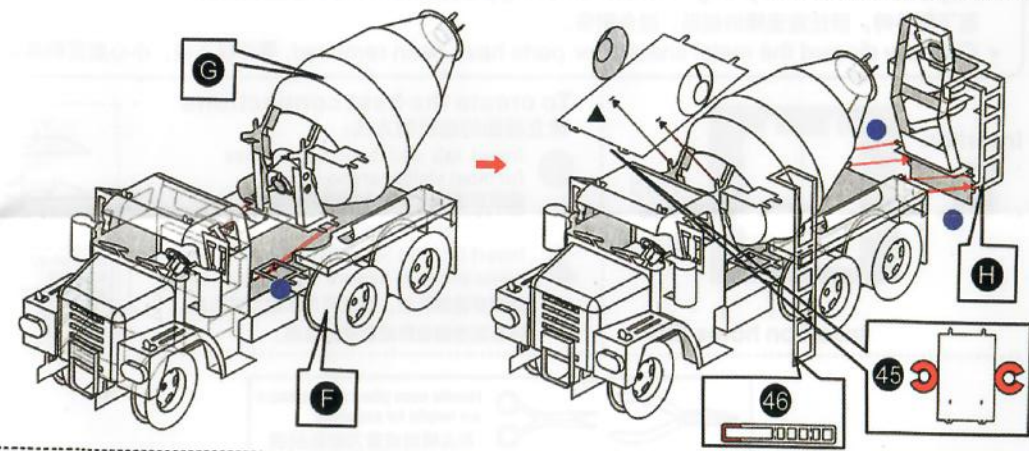
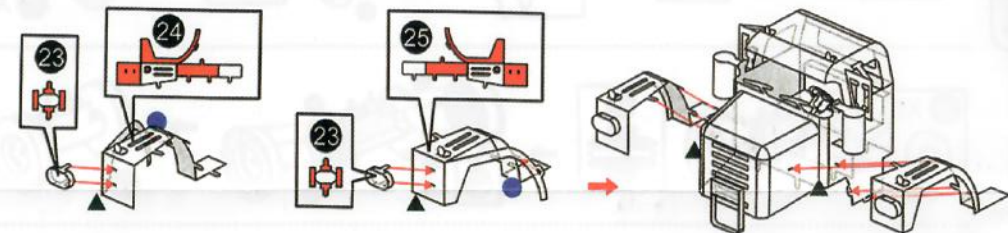
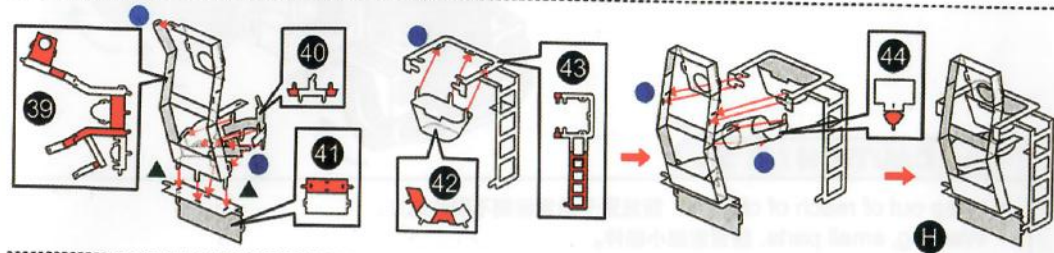
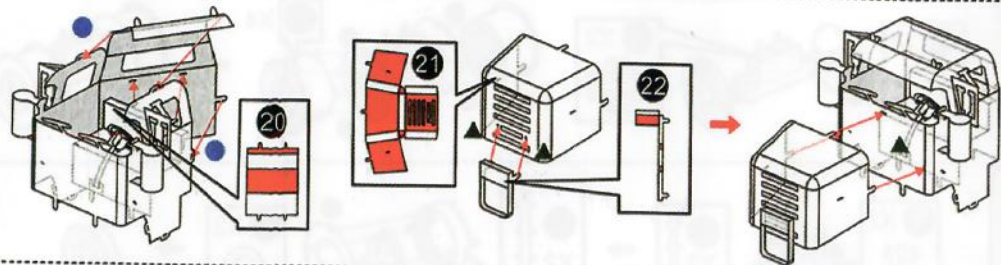
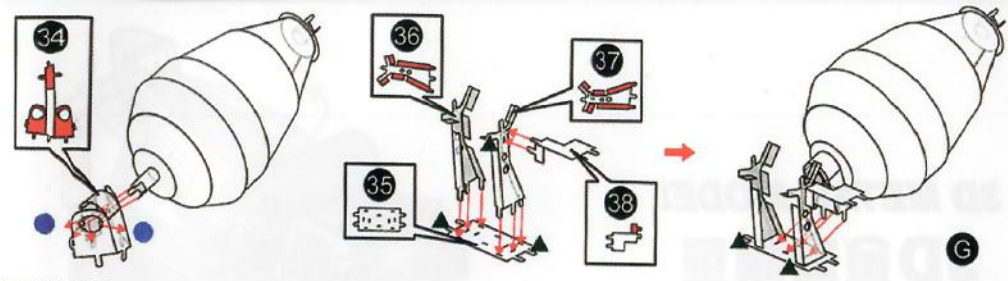
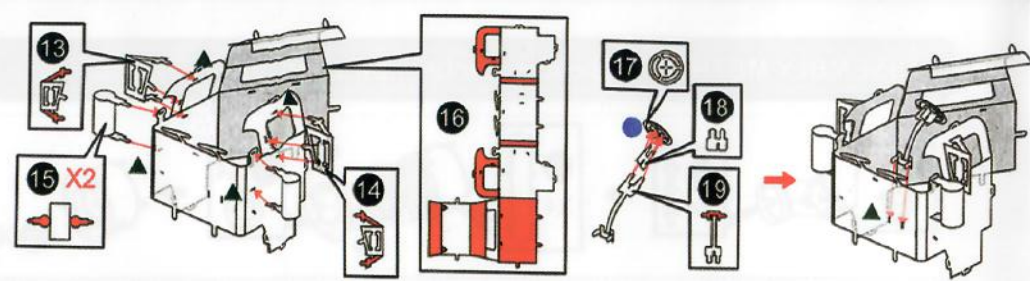

Complete/完成